

Produktdatenblatt – Swing Kollektion
product data sheet – Swing Collection

Swing 30/70P



Furniere / veneers

- Ahorn / maple
- Nussbaum / walnut

Stahlelemente / steel parts

- RAL 9016

Elektrik / electrics

1x E-27 max 60W
 220V-240V ~/50Hz-60Hz

Abhängung / suspension

3 m

Verpackung / packaging

Gewicht / weight 3,25kg
 Volumen / volume 0,110m³
 Maße / dimensions 38x38x78cm

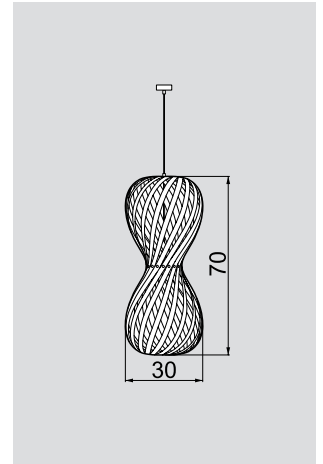

Swing 30/70S



Furniere / veneers

- Ahorn / maple
- Nussbaum / walnut

Stahlelemente / steel parts

- RAL 9016

Elektrik / electrics

1x E-27 max 60W
 220V-240V ~/50Hz-60Hz

Kabellänge / cable length

3 m

Verpackung / packaging

Box 1
 Gewicht / weight 6,75kg
 Volumen / volume 0,110m³
 Maße / dimensions 38x38x78cm

Box 2
 Gewicht / weight 2,75kg
 Volumen / volume 0,048m³
 Maße / dimensions 20x20x120cm

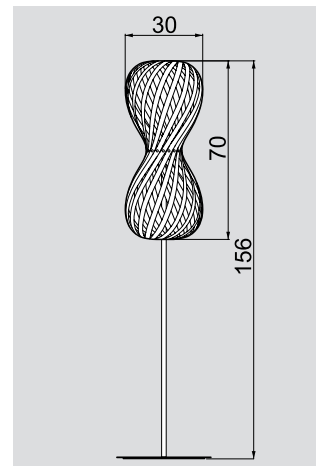

Swing 56/32P



Furniere / veneers

- Esche / ash

Stahlelemente / steel parts

- RAL 9016

Elektrik / electrics

1x E-27 max 60W
 220V-240V ~/50Hz-60Hz

Abhängung / suspension

2 m

Verpackung / packaging

Gewicht / weight 4,50kg
 Volumen / volume 0,144m³
 Maße / dimensions 60x60x40cm

